



# National Power Corporation

## SUPPLEMENTAL /BID BULLETIN NO. 1 to the Bid Documents for the:

**SUPPLY AND DELIVERY OF TRANSMISSION LINE HARDWARES FOR OCCIDENTAL MINDORO SUBSTATION AND 69KV TRANSMISSION LINE UNDER PR NO. S1-OCS24-019/REF NO. PB240820-JD00369**

**14 AUGUST 2024**

All prospective bidders and authorized copyholders of the Bid Documents of the above-mentioned project are hereby informed of the changes of the following:

### A. BID SUBMISSION/OPENING

FROM	TO
20 August 2024 9:30 A.M. Kaňao Function Room	22 August 2024 9:30 A.M. Kaňao Function Room

### B. SECTION VI – PART I – TECHNICAL SPECIFICATIONS – TS-5.0 DRAWINGS AND DOCUMENTS TO BE SUBMITTED

From	To
a.2 Letter of Confirmation from the Manufacturer that a local agent or representative is available to provide "After Sales Service" to the supplied components/parts/accessories during and after the warranty period. Name, address and contact number shall be provided.	a.2 Letter of Confirmation from the Manufacturer that a local agent or representative is available to provide "After Sales Service" to the supplied components/parts/accessories during and after the warranty period. Name, address and contact number shall be provided. <b>(For items 11, 12, 13, 14 &amp; 15)</b>

### C. SECTION VI – PART I – TECHNICAL SPECIFICATIONS – TS-5.0 DRAWINGS AND DOCUMENTS TO BE SUBMITTED

From	To
b.1 "Certificate of Origin" from the Manufacturer	<b>c.1 "Certificate of Origin" from the Manufacturer (For items 11, 12, 13, 14 &amp; 15)</b>
b.2 "Warranty" Certificate for One (1) year against factory defects/workmanship.	<b>c.2 "Warranty" Certificate for One (1) year against factory defects/workmanship.</b>



#### NATIONAL POWER CORPORATION

Gabriel Y. Itchon Building  
Senator Miriam P. Defensor-Santiago Avenue (formerly BIR Road)  
corner Quezon Avenue, Diliman, Quezon City 1100, Philippines  
Tel. Nos. (632) 8921-3541 to 80 • Fax No. (632) 8921-2468  
Website: [www.napocor.gov.ph](http://www.napocor.gov.ph)



#### D. SECTION VI – PART II – TECHNICAL DATA SHEETS

##### DELETION OF:

"If the part number(s) indicated by the bidder under the "Supplier's Data" column is not the same to the part number indicated under the "NPC's Requirement column", the bidder will submit/attached the corresponding Service Bulletin issued by the OEM/Authorized Manufacturer or any documents that will support it, such as but not limited to the Catalogue/Brochures/Parts Manual". Provided that "Certification from \*Supplier that the item(s) offered is the same as required in the Tender Documents" must be submitted as post qualification requirement.

##### Note:

\*Supplier refers to those mentioned/covered under a.2.4  
*TS-DRAWINGS AND DOCUMENTS TO BE SUBMITTED*  
(Section VI – Technical Specifications)

(a.2.4 Distributor/Dealer, a Certificate of Authorized Distributorship/Dealership from the OEM or Authorized Manufacturer of OEM Parts or Licensee of the OEM)  
(The authority can be acquired from OEM, Manufacturer of OEM Parts or Licensee of the OEM)

#### E. ADDITIONAL INFORMATION FOR CROSSARMS

See attached Drawings "5 pages"

All other terms and conditions shall remain the same.

For the information and guidance of all authorized copyholders of the Bid Documents and prospective bidders.

For the Bids and Awards Committee:

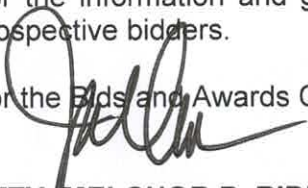
  
**ATTY. MELCHOR P. RIDULME**  
Senior Vice President & COO  
and Chairman, Bids and Awards Committee

# STEEL CROSS ARM 70 mm x 140 mm x 2438.4 mm

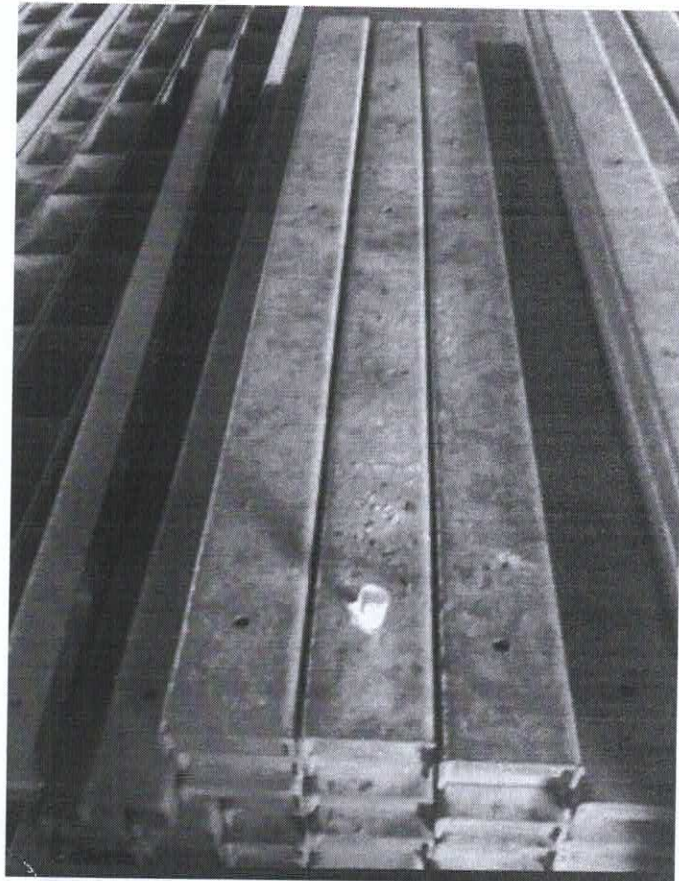
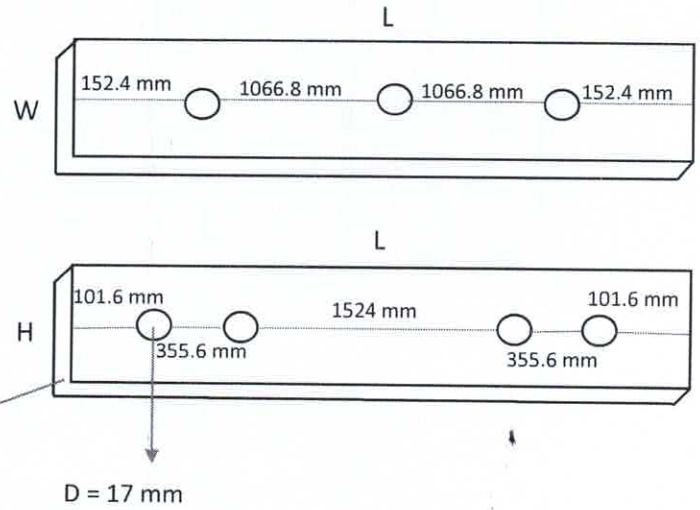
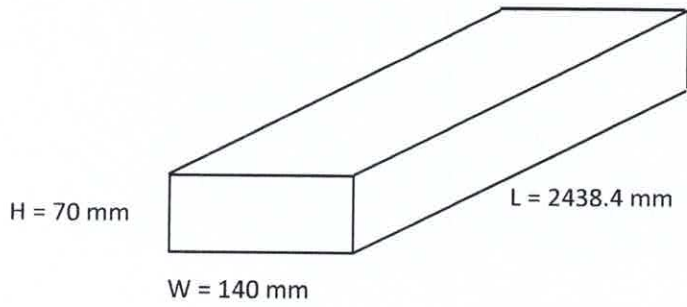

# STEEL CROSS ARM 70 mm x 140 mm x 3048 mm

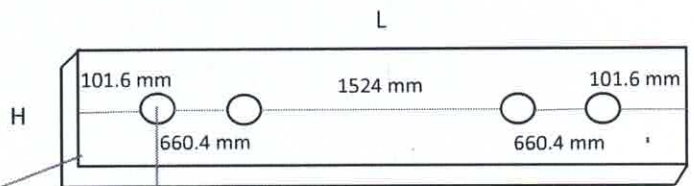
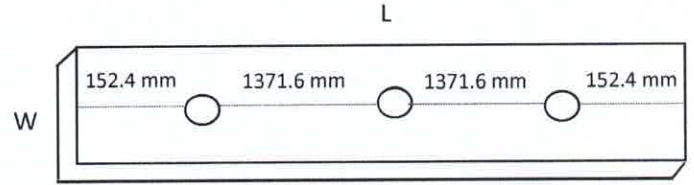
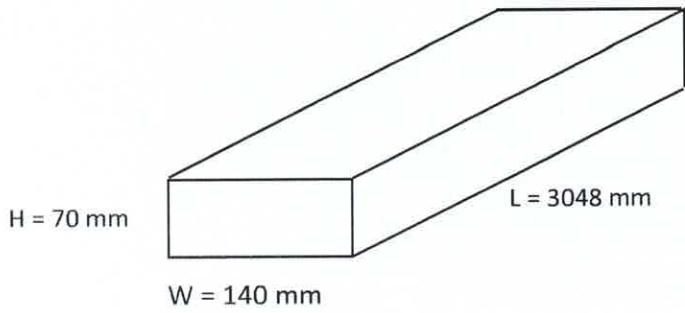

$T = 6\text{ mm}$

$D = 17\text{ mm}$



# STEEL CROSS ARM 70 mm x 140 mm x 3962.4 mm

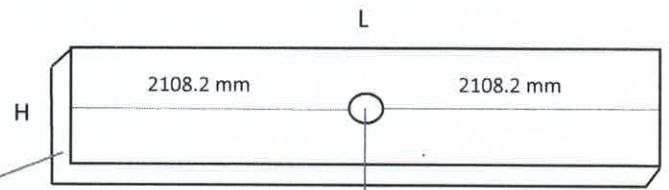
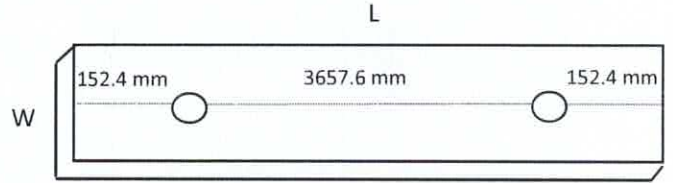
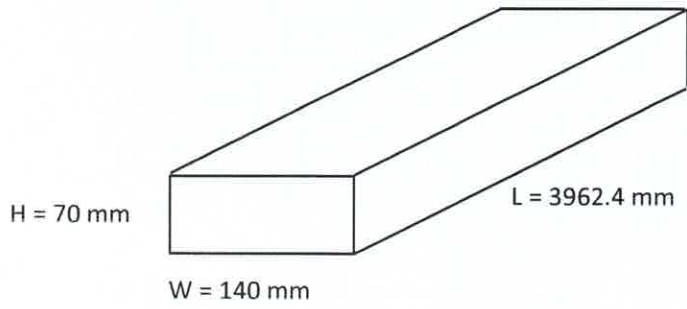

$T = 6\text{ mm}$

$D = 20\text{ mm}$

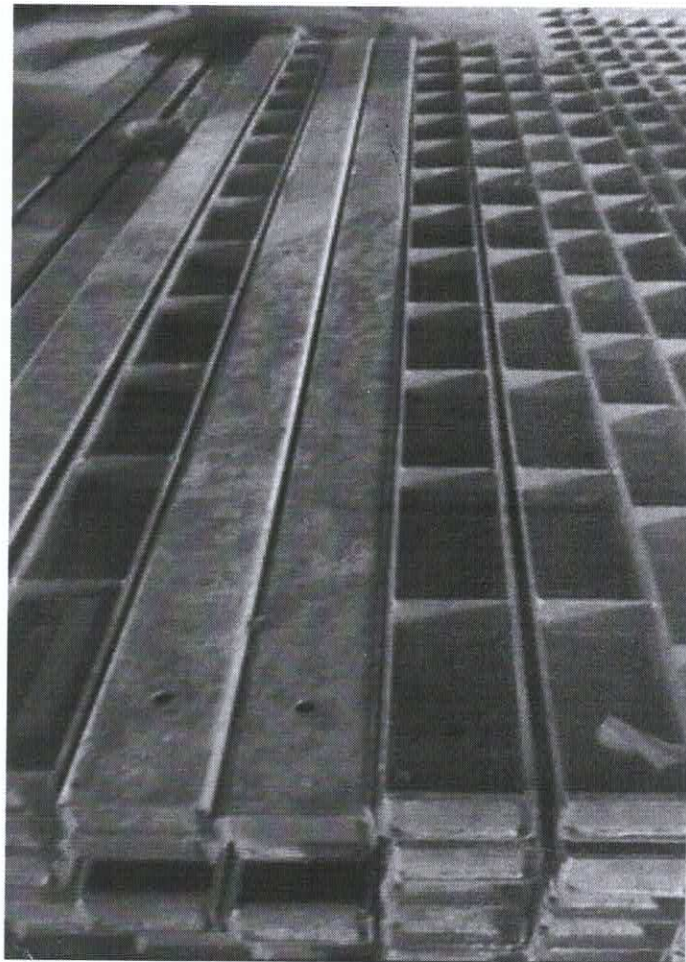

# STEEL CROSS ARM 70 mm x 140 mm x 5791.2 mm

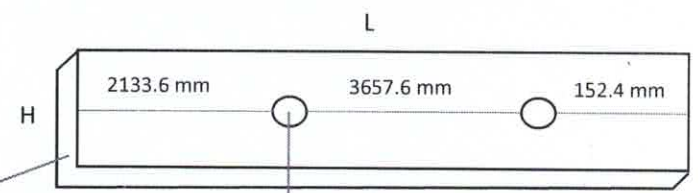
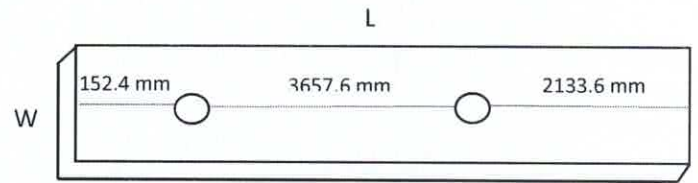
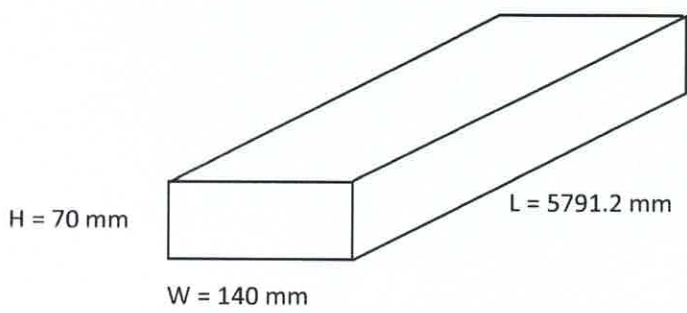

$T = 6\text{ mm}$

$D = 20\text{ mm}$



**STEEL CROSS ARM 70 mm x 140 mm x 7010.4 mm**

